

# Installation and Maintenance Manual

## *Swing Gate Operators*

Models: GDS 4,6,7

*Made in Australia from Australian & quality imported components*



8 Bennet Avenue Melrose Park SA 5039  
Phone 08 8374 3466

A.B.N. 62 059 806 405

Nov 2014



N14870

# CONTENTS

| Section no: |  | page no: |
|-------------|--|----------|
| 1           | Safety Precautions                           | 3        |
| 2           | Specifications                               | 4        |
| 3           | Installation                                 | 4-8      |
|             | Electrical Cabling & Mechanical Installation |          |
|             | Electrical Connections                       |          |
|             | Mode Selection                               |          |
|             | Variable Speed Drive                         |          |
| 5           | Commissioning                                | 9        |
| 6           | CB-6 control board layout                    | 10       |
| 7           | Schematic wiring diagram                     | 11       |
| 8           | Manual release instruction                   | 12       |
| 9           | Maintenance details                          | 13       |
| 10          | Warranty                                     | 14       |

# 1. SAFETY PRECAUTIONS



**WARNING! FAILURE TO FOLLOW THESE SAFETY PRECAUTIONS AND INSTALLATION INSTRUCTIONS COULD RESULT IN INJURY OR DEATH AND/OR DAMAGE TO PROPERTY AND EQUIPMENT.**

- Appropriately licensed and competent personnel only should install the automation equipment.
- The operators are designed specifically to open and close sliding gates or doors and should not be used for any other purpose.
- Before commencing installation, read through this installation manual.
- Check that the operator and controls are in new condition and have not been damaged in transit.
- Check the gate or door and it's associated support posts and walls to protect against shearing, compression and other various traps which could cause serious injury or death. Take into consideration the general installation and surrounding environment.
- Check the gateposts or mounting structure has the necessary strength and rigidity to support the operator and the load of the opening and closing gate motion.
- **Gate leaves over 2.4m in length, should have some form of electro mechanical, or magnetic locking fitted to avoid possible damage to gearbox from forcing due to vandalism, negligence, ramming.**

**CAUTION!**



**Always incorporate the appropriate Photo Electric Cells, Induction Loops and any other safety devices to protect both equipment and personnel. Extra caution should be employed when using operator in auto close mode.**

- Display any necessary signs to indicate any danger areas and automatic operation of the gate or door.
- The operators are not designed to be used in any hazardous areas or areas subject to flooding etc.
- All electrical connections and wiring must be performed with AS/NZS 3000-2007 as the guidelines. (Or its counterpart for other countries outside of Australia and New Zealand)

## **WARNING! ELECTRICITY CAN KILL**

The manufacturer of the automation equipment is not responsible for the damage which may be caused to either the operator, gate or door and any other person or equipment when: -

- Wrong or poor installation practices were performed.
  - No or inadequate safety devices were used.
  - Either the surrounding structure or the gate or door strength and rigidity was not sufficient for the task in hand.
  - Inefficient locking devices were employed.
  - Poor maintenance on the equipment.
  - Any other circumstances beyond the manufacturers control.
- Isolate power before attempting any maintenance, qualified personnel only to carry out maintenance
  - Only original spare parts are to be used should there be a requirement for them.
  - Keep loose clothing and hands clear of the gate whilst in operation or potentially able to be operated.
- The installer should provide all information concerning the use of the automation equipment as well as instructions regarding the manual override and maintenance procedures to the users of the system

## 2. SPECIFICATIONS (subject to change without notice)

|   | <b>GDS 4</b>                 | <b>GD 6,7</b>                       |
|---|------------------------------|-------------------------------------|
| <b>MOTOR:</b>                                       | 230v 180w                    | 230v 370w                           |
| <b>DUTY CYCLE:</b>                                  | 100%                         | 100%                                |
| <b>SPEED:</b>                                       | 8-12 sec/90°<br>(ADJUSTABLE) | 10-13 sec/90°<br>(ADJUSTABLE)       |
| <b>WEIGHT OF OPERATOR :</b><br>(NOT INCLUDING ARMS) | 37.5 kgs                     | GDS 6 = 60.5kgs    GDS 7 = 80.00kgs |

GDS 4 DIMENSIONS

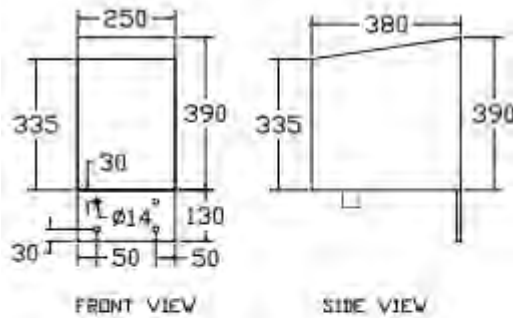

GDS 6,7 DIMENSIONS

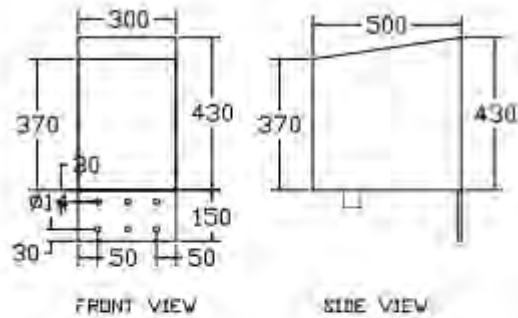

GDS 4 ARMS

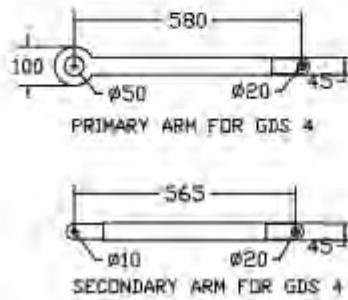

GDS 6,7 ARMS

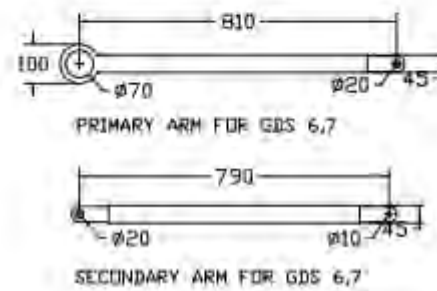

### WIRING REQUIREMENTS:

- 240v on Control Box side.
- 3 – 1.5mm<sup>2</sup> cables to each operator (mains voltage plus earth). *Must be Shielded Cable.*
- 3 – Low voltage cables to each operator for limits (all to be shielded cable if over 8m runs).
- Control input cables, Output signal cables, Lock cabling, (all to be shielded cable if over 8m runs).

### INSTALLATION DETAILS:

After reading the previous sections in this manual, and having checked for suitable installation, proceed as follows:-

#### Electrical Cabling

- A suitably rated Isolator and 240v non-earth leakage protected power supply should be available near to where the gate operator control box is to be mounted.
- If electrical cabling needs to be run across the driveway (for dual operators or where the single gate operator is on the opposite side to the control box) then ensure the appropriate number of cables (see wiring requirements) are run in conduit and are installed at the correct depths and manner for both the mains voltage cables and low voltage cables.

# MECHANICAL INSTALLATION



- Firstly determine which gate rail the operator arm is to be mounted to.
- Run a level from the top of the gate rail across to where the operator is to be installed onto either wall or post.
- Draw a horizontal line on the post or wall, which becomes the mounting position of the operator where the top mounting studs are in line with your level line, so level with the top of the bottom gate rail.



- Ideally weld the mounting plate provided to the steel post and use extra strengthening brackets/gussets if necessary to ensure a solidly fixed mounting plate (i.e. strengthening brackets may be required if post is less than approximately 150mm wide).

- If mounting to masonry or similar, either weld tags onto the mounting plate or as a last resort fix the operator straight to the wall preferably using suitable chemical type anchors to ensure a firm mounting is obtained.
- Fixing without mounting plate ensure spacers (i.e. washers or nuts) are used between the wall and the operator to allow for the cover to fit.



- Lift operator into position and bolt to the mounting plate.  
**\*PLAN YOUR LIFT, IF NO MECHANICAL AIDS ARE AVAILABLE, FIND SOMEONE TO ASSIST !**
- Turn the knurled knob anticlockwise and position arms so they are approx. 10 to 15° off of being straight when the gate is fully closed.



- Mark where the gate bracket is to be fixed onto the gate rail, ensuring both arms are in a horizontal, level plane.
- Fully open the gate and realign the gate bracket to the marked position to ensure there is adequate side room for the arms to swing. If not, the last 2 steps may have to be repeated using a cut down secondary arm.
- Now attach the gate bracket to the gate rail with bolts suitable to handle the load and forces the gate and operator provide. (normally 10mm).

# ELECTRICAL CONNECTIONS

## Operators:-

- Connect the 3 motor wires to the motor terminals plus earth and shielded cable to the earth terminal.
- Connect the 3 low voltage limit switch wires to the terminal strip provided. If the run is over 8m and shielded cable is used, connect shield to the earthed chassis.
- The common limit switch wire goes to the centre terminal.

## CONNECTION TO CONTROL BOARD:-

### Supply

Connect a non earth leakage protected 10A 240v supply to Din Rail terminals labelled A & N  
Connect earth to earth terminal.

### Motor Wires

Connect the shielded motor cable to Inverter terminals. Connect earth and shield to Earth Stud.

### Control

Connect low voltage limit switch wires to limit switch terminals on circuit board. Note the common terminal and open/close terminals for motor one and motor two. Connect the shield (if used) to earth.

### Control Inputs

The P.E, OPN and STP inputs require a normally closed switch contact and therefore should be shorted to the COM terminal if not used. This is done via bridging links already on the circuit board (bottom left corner) The CLS, OSC and PED inputs require a normally open switch contact and therefore should be left unconnected if not used. All the switch inputs of this control board including the limit switch inputs require a switch contact only. Do not connect any switches which provide a voltage to the control board as this will damage the control board. If the inputs are 12/24v or has long wiring associated with it use an IM-1 module to isolate it from the control board's input. The IM-1 is available from the manufacturer.

### Powering Accessories

Accessories which require a 24v AC supply can be powered from the transformer output used to power the control board via the isolated 24v AC supply which is connected to the DIN rail terminals as labelled. However, the transformer's current capacity must be checked to allow for the extra power required by the accessories. Never use the supply connected to the 24vAC supply terminals to power any accessory as this can interfere with the control boards operation.

### Locks & Lights

Use the lock output terminals on the din rail to switch the 12 volts to an electric lock (if fitted). The load switched by the lock output terminals must not exceed 30v AC / DC @ 5Amps. If a electro magnetic lock is used, change one wire on the control board lock output to the normally closed output. Use the light relay module (if fitted) to switch the applied voltage to a light. The load switched by the light relay module must not exceed 240v A.C / 30v DC @ 10 Amps.

## **MODE SELECTION**

Using the mode selection dip-switches select the desired operating modes. Note the times associated with the parameters marked with an \* can be changed. The auto-close times can be changed using the procedure in the following section. See the detailed installation manual for details on how to change the other parameters.

### POSITION 1 Synchronising Delay

OFF - No delay

ON - Motor 1 starts to open 2 seconds\* before Motor 2 and Motor 2 starts to close 2 seconds\* before Motor 1.

### POSITION 2 Pulse Lock Output

OFF - Lock output is activated for the entire motor drive cycle.

ON - Lock output pulses for 0.3 seconds\* at the start of each drive cycle.

### POSITION 3 Light Outputs Warning

OFF - Optional light module controls a light with timer which turns light off after 60seconds\*.

ON - Optional light module controls a warning light which activates whenever motors are on.

### POSITION 4 Swipe Mode (OSC Input)

OFF - OSC input terminal has standard Open, Close, Stop action.

ON - OSC input terminal will only open the door/gate. The input also resets the P.E triggered auto-close mode so that the P.E input will need to be triggered again before a P.E auto-close cycle will be initiated.

### POSITION 5 M 2 Outputs Status

OFF - The M2 output controls second motor

ON - The M2 output controls status lights

### POSITION 6 P.E Stops Close Cycle

OFF - Activating the P.E input while motors are closing causes the motors to reverse.

ON - Activating the P.E input while motors are closing causes the motors to stop but not reverse.

### POSITION 7 P.E Stops Open Cycle

OFF - Activating the P.E input while motors are opening is ignored by the controller.

ON - Activating the P.E input while motors are opening causes the motors to stop.

### POSITION 8 P.E Triggered Auto Close

OFF - Not selected

ON - Selects the P.E triggered auto-close mode which causes the motors to auto-close if the P.E input is activated then released. (Auto-close delay time is 0 seconds\*)

### POSITION 9 Pedestrian Auto-Close

OFF - No pedestrian access auto-close

ON - Selects auto-close in the pedestrian access mode. (Auto-close delay time is 15 seconds\*)

### POSITION 10 Standard Auto Close

OFF - Not selected

ON - Selects standard auto-close mode which will close the motors after fully opening.(Auto-close delay time is 30 seconds\*)

### Setting Cycle Timers & Auto Close Times

The control board has pre-set cycle times which are used to set the maximum time the controller will drive the motors in the open and closed directions. The pre-programmed time for the open and close cycle timer's is 60 seconds. The control board also has a pre-set pedestrian access time of 5 seconds which is intended to open the motor connected to M1 output only part way. If these default times do not suit your needs simply use the procedure below to adjust them. Note the same procedure can be used to adjust the auto-close times.

1. Place the slide switch into the "set" position
2. Adjust the timer's value by pressing and holding the required push button for the desired time.
3. Repeat step 2 for the next timer (if desired).
4. Place the slide switch back into the "RUN" position.
5. Test operation.

Make sure that the slide switch is placed back into the "RUN" position before testing the new timer value.

As you can see the procedure used to set each timer's value is the same only the push button used changes. Each push button is clearly labelled underneath as to which timer's value it sets. Note when setting the OPEN, CLOSE and PEDESTRIAN cycle times the controller will drive the motors as if a "real" cycle is being executed. The difference being that the motors will stop as soon as the button is released or the limit switches are reached. The OPN status LED on the control board will flash at 1 second intervals to assist setting times. Note when setting the OPEN and CLOSE cycle times when limit switches are used, release the push button a few seconds after the limit switch cuts motor power. This allows for the motors to slow down over the life of the operators without the need to adjust again.

### VARIABLE SPEED DRIVE (INVERTER)

- The variable speed drive unit will, for each motor, ramp up the speed of the operator and then ramp down prior to closing. It must be remembered that the limit switches are to be set in a position which initiates the ramp down time. Therefore, the limit switches need to operate much sooner than when there is no variable speed drive unit.
- The accelerate and decelerate times have been set in the factory for the normal installation, but can be changed if necessary. Similarly, the speed that the gate operates at has also been set but can be changed (up to approx 70Hz).
- NOTE changing the speed will change the position the gate will end up in its fully closed and open position. (Unless limit switch cams are also adjusted accordingly).

|                   |               |         |
|-------------------|---------------|---------|
| Accelerate time   | (FN01)        | 5.0sec  |
| Decelerate time   | (FN02)        | 2.5 sec |
| Opening Frequency | (main screen) | 50Hz    |
| Closing Frequency | (FN08)        | 30Hz    |

To change accelerate time:  
Press DSP/FUN button  
Use arrows to select FN01  
Press DATA/ENT  
Use arrows to select new time  
Press DATA/ENT  
Press DSP/FUN

- To change decelerate time: As above except select FN02
- To change closing speed: As above except select FN08
- Opening speed of operator: When display is flashing and showing Hz, use arrows to raise or lower the Hz figure. NOTE: Frequency upper limit has been set to 70Hz.



## 5. COMMISSIONING

- Position the gate so it is half way, tighten manual release knob to the point where the gate will just start to be driven but the clutch will slip if the gate accidentally hits the gate stop too hard while setting up the limits.
- Power up board and with gate in the half way position, press transmitter or manual control switch so operator drives gate.
- The first pulse will always open gate green open LED will flash (top right hand corner) if it does not, then reverse two of the motor wires. Once the gate reaches its full open position, the green led will stay on, also on closing, the red close led will flash while closing and then stay on once reaching it`s full open position.
- **If dual gates**, leave one side disconnected (by putting both cams on limit switches) so adjustment can be done on one side at a time. Once each side is set, you can run both gates together then do final adjustments to suit.
- Check which limit switch stops gate in each direction and adjust cams so gate will stop in the fully open and closed positions.
- Limit switches should not switch off the gates too soon (before reaching the stops) and conversely not too late, so the torque limiter is operating.
- Once happy with limits settings, now set the travel time. Change the run/set switch (mode selection 1 switch) to set. Once in set, run the gate from either the full open or closed position by pressing either the opn (open), or the cls (close) buttons. Keep the button pressed for the complete travel distance of the gate then release approx 5 seconds after the gate has stopped in its full open or closed position. This has to done for both the open and close cycles.
- Tighten manual release knob and check that the torque limiter slips if there is an obstruction in the way of the gate but there is enough drive to overcome environmental conditions etc.
- Check that all safety devices work as designed and the external locks etc lock the gate.
- Install cover using screws screwed in the front and side to hold cover firm.
- Provide full details to the owner concerning the operation, relevant maintenance and disconnect details.

# CONTROL BOARD LAYOUT FOR INVERTER CONTROLS

FIG. 4

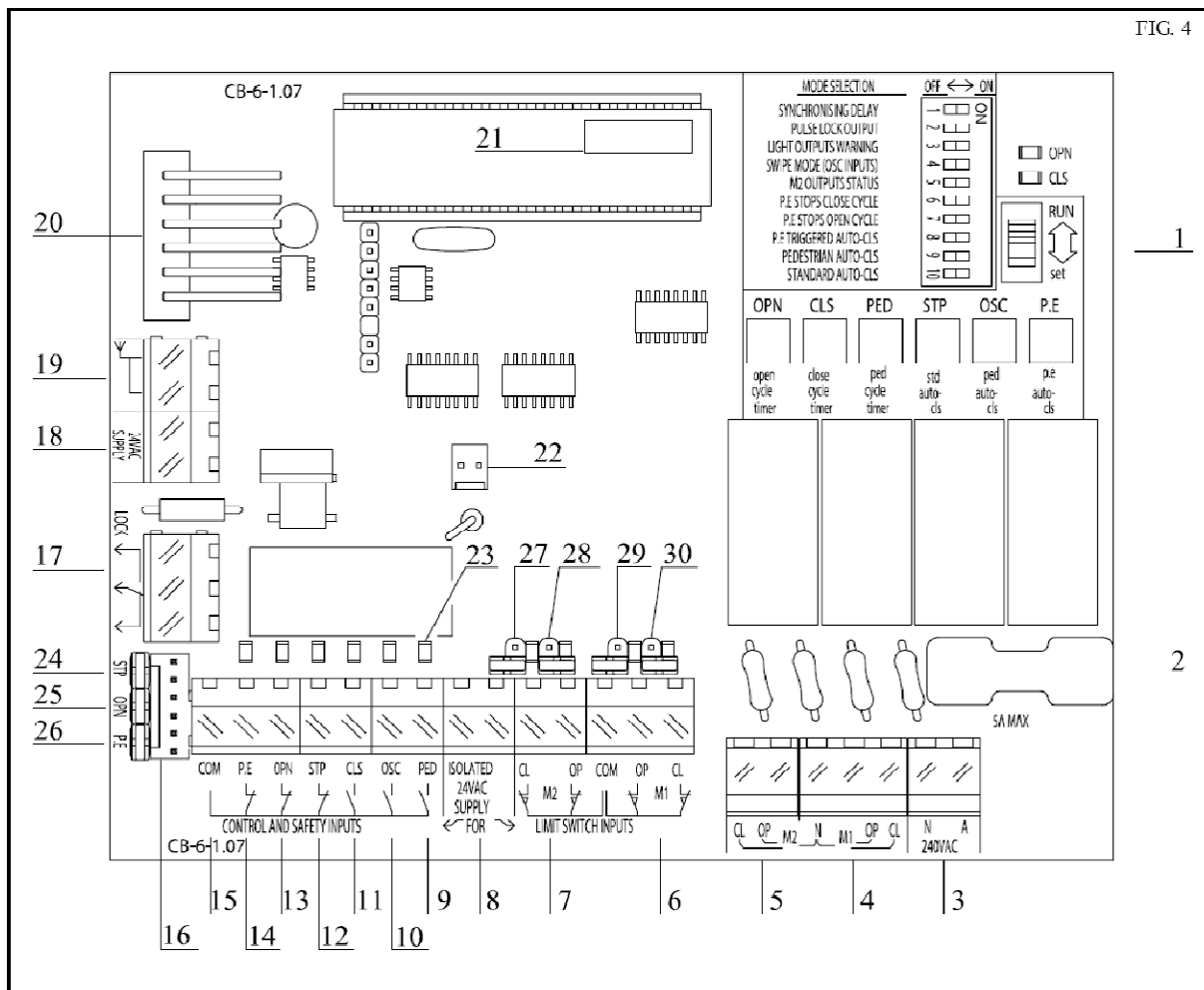

- |  |   |
|--|---|
| <ol style="list-style-type: none"> <li>1. Mode Selection and Adjustment</li> <li>2. Protection Fuse</li> <li>3. Inverter Input Terminals</li> <li>4. Motor 1 Drive Output Terminals for Inverter</li> <li>5. Motor 2 Drive Output Terminals for Inverter</li> <li>6. Motor 1 Limit Switch Inputs</li> <li>7. Motor 2 Limit Switch Inputs</li> <li>8. Terminals for Isolated 24vAC Supply for Limit Switch and Control Inputs</li> <li>9. Pedestrian Access Control Input</li> <li>10. Open/Stop/Close Control Input</li> <li>11. Close Control Input</li> <li>12. Stop Control Input</li> <li>13. Open Control Input</li> <li>14. Photoelectric Safety Beam Input</li> <li>15. Common Terminal for Inputs [9] Thru [14].</li> <li>16. Control Input Harness Connector</li> </ol> | <ol style="list-style-type: none"> <li>17. Electric Lock Control Terminals</li> <li>18. Terminals for 24vAC Supply for Control Logic</li> <li>19. Plug In Receiver's Antenna Terminals With Optional Shield</li> <li>20. Connector for Plug-In Receiver (not shown)</li> <li>21. Firmware Version Label</li> <li>22. Light Control Relay Interface Connector</li> <li>23. Input Status L.E.Ds.</li> <li>24. Stop Input Jumper</li> <li>25. Open Input Jumper</li> <li>26. PE Beam Input Jumper</li> <li>27. M2 Close Limit Jumper</li> <li>28. M2 Open Limit Jumper</li> <li>29. M1 Close Limit Jumper</li> <li>30. M1 Open Limit Jumper</li> </ol> |
|--|---|

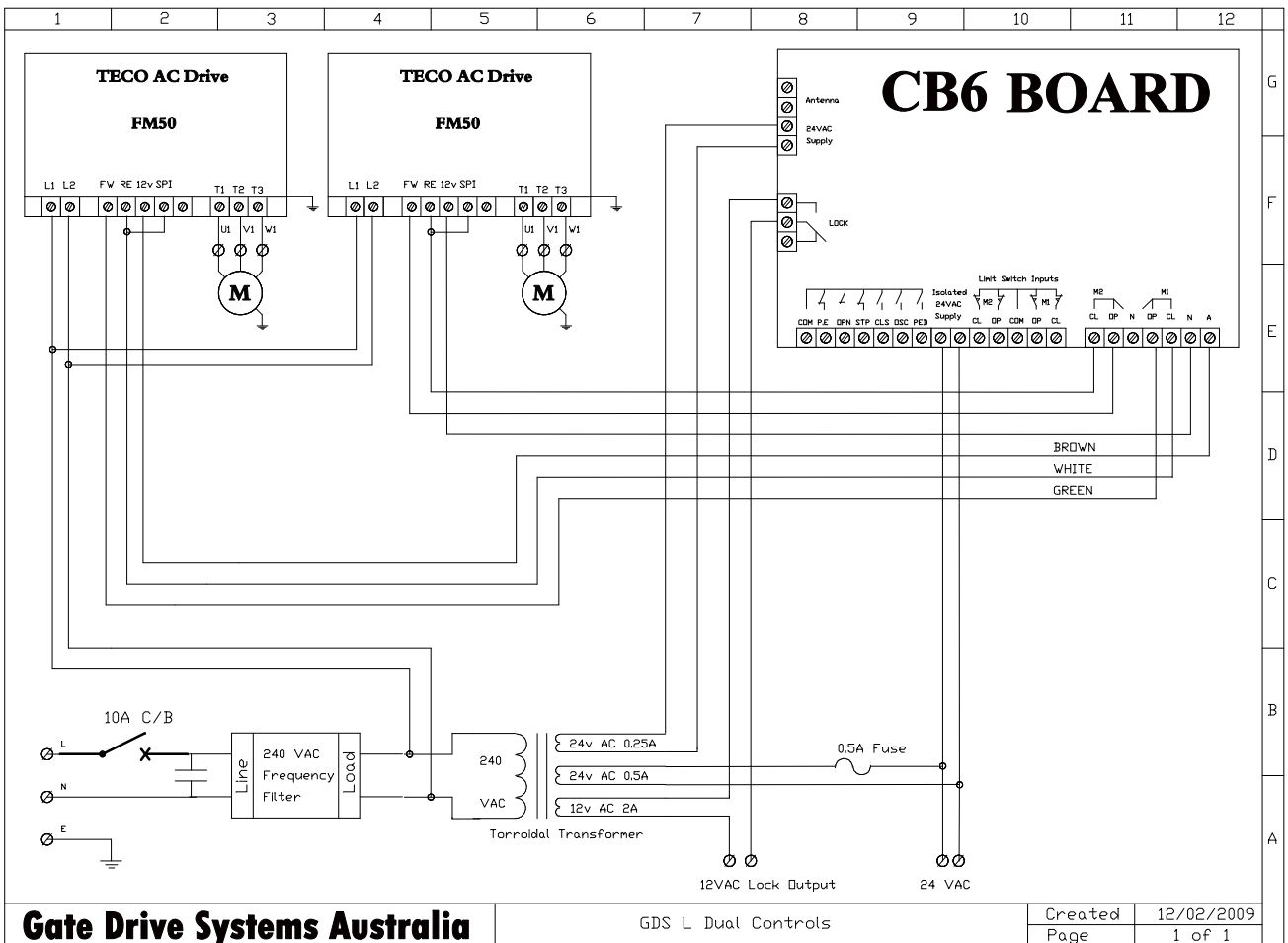
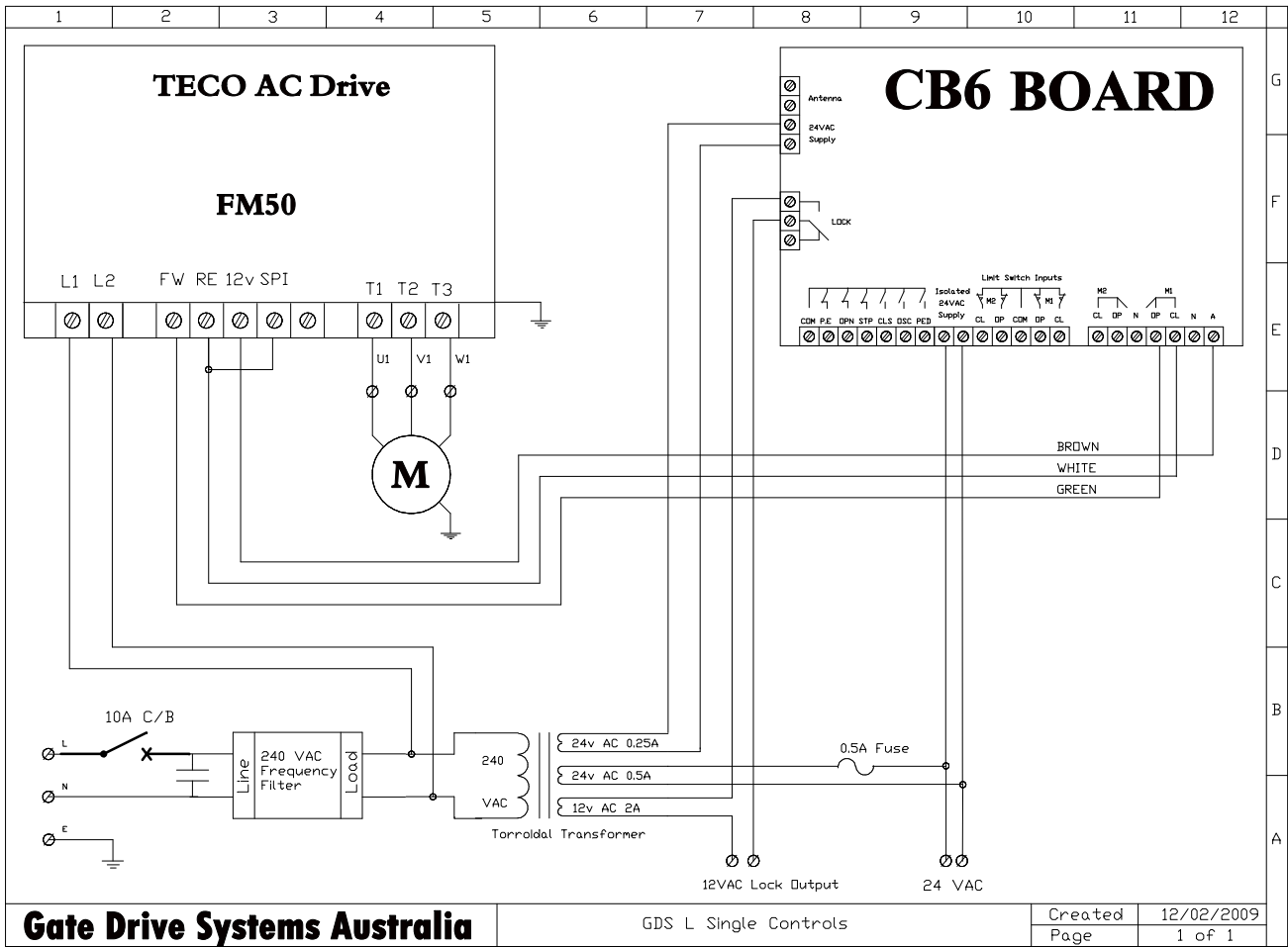

## 8. MANUAL RELEASE INSTRUCTIONS

- Turn power off to the control box and isolate. Using key to open side door on gate operator cover,



- Turn knurled disc anticlockwise for arm to be released from gearbox.



- If a magnetic lock is fitted, turn off the power to the control box.
- If an electric lock is fitted, release with the electric lock key provided.



- The gate will now open manually. Ensure gate is held firm so it does not close on someone or something.
- To engage drive, turn knurled knob clockwise until tight. Close and lock cover door with key.

## 9. MAINTENANCE DETAILS



### WARNING!

**Failure to maintain equipment may result in injury or death and/or damage to property and equipment**

Recommended maintenance to be performed on the operator and gate are as follows:-

|  |                 |
|--|-----------------|
| Operator performs over 150 cycles a day        | each month      |
| Operator performs between 100-150 cycles a day | every 2 month   |
| Operator performs between 50-99 cycles a day   | every 4 months  |
| Operator performs between 20-49 cycles a day   | every 6 months  |
| Operator performs under 20 cycles a day        | every 12 months |

Date: .....

Site Name: .....

Site Address: .....

**Before** commencing maintenance on the operator, isolate the electrical supply to ensure operator will not run inadvertently.

- Gate hinges in good condition and oiled/greased .....
- Gate swings freely.....
- Gate stops in good condition.....
- Gate operator mounting bolts tight .....
- All arm joints lubricated and moving freely with nylock nuts tight on bolt .....
- No oil leaks from gearboxes .....
- Gearbox drive cogs tight on shafts.....
- Gearbox mounting bolts/nuts tight.....
- Inside operator and control box clean .....
- 'Baygon' Surface Spray around operator and control box (not on electronics) ....
- Torque limiter chain slightly oiled .....
- All electrical connections tight.....
- Limit Switches operate in appropriate positions .....
- External safety devices work effectively .....
- External locks operate correctly.....
- General operation i.e. speed, auto close etc normal.....
- Arm taper lock grub screws tight.....
- Wash down of control box and cover (particularly near corrosive/sea environments)

Comments .....

Service performed by.....

## 10. WARRANTY

- a. Gate Drive Systems Australia warrants that the goods manufactured by it shall be free from defect in manufacture for a period of 12 months from the date of invoice. Should any fault occur within that period as a result of faulty workmanship or materials, Gate Drive Systems Australia will make all necessary repairs, or at its discretion replace the product at no charge to the Customer except for installation and freight. The appropriate Serial Number must be quoted for all warranty claims.
- b. For the goods not manufactured by Gate Drive Systems Australia, we shall pass on the manufacturer`s warranty to the Customer from the date of invoice. It is the manufacturer`s discretion to repair or replace goods deemed to be defective as a result of faulty workmanship or materials.
- c. All goods must be returned to Gate Drive Systems Australia or its representative for inspection or testing to assess if a claim is justified. It is the responsibility and at the cost of the Customer, to return the goods for inspection and freight costs are the responsibility of the Customer.
- d. The warranty is negated and will not apply in the following circumstances:-
  - i. If no proof of date of purchase can be produced.
  - ii. If the product has been used in a manner beyond its design parameters.
  - iii. If the product is tampered with or repaired by personnel not authorised to do so.
  - iv. In respect of loss or damage caused by rough treatment.
  - v. If the product is not used and maintained in accordance with instructions or recommendations listed in this Installation and Maintenance Manual.
  - vi. In respect of loss or damage caused by an Act of God or any other cause not within the manufacturers control.
- e. Goods returned under warranty for repair or testing will incur a charge to be fixed by the manufacturer if no fault is found.
- f. The Customer shall bear freight charges for removing and returning the goods for inspection and for the delivery and installation of any replacement or repaired product from a justified warranty claim.
- g. Save for the express conditions and warranties herein contained all other conditions or warranties (whether as the quality, fitness for purpose or any other matter) expressed or implied by statute, common law, equity, trade custom, usage or otherwise are hereby expressly excluded provided that nothing in these terms and conditions shall exclude or limit any breach or condition implied by law, the exclusion or limitation of which is not permitted by law.